

1000-MR2-1

Mobile Refrigerated Cart



- The Alto-Shaam Mobile Refrigerated Cart is not just a refrigerator on wheels, but a well designed and efficient system for storing and transferring refrigerated food products.
- Condensate from the cooling coil is diverted to a condensate evaporator, therefore, it is unnecessary to have an alternate means of water disposal.
- Waste heat from the condensing unit efficiently evaporates (or vaporizes) condensate water from the evaporator and saves energy and eliminates potential service problems.
- Full perimeter bumper, flush transport handles, heavy duty casters along with the cart's reduced height provide easy mobility.
- A helicoil power cable keeps the power cord is out of the way during transportation.
- Stainless steel surfaces resists corrosion.
- Easy to clean interior and base.
- Full access front gives the operator 1300 mm of clear, unobstructed storage.
- All mechanical equipment is easily accessible for ease in servicing.
- Non-tilt pan slides.

Stainless steel exterior and door, fully insulated with 60 mm of polyurethane. Self-closing lockable door is hinged right as standard and includes a removable magnetic door gasket. The cart is supplied with twelve (12) sets of non-tilt pan slides.

Cart is factory preset to operate between -2°C and +4°C. High ambient (43°C) bottom mounted refrigeration system utilizes R134a refrigerant, generating 1584 BTU (399 KCAL) per hour. A LED display monitors the inside temperature. Audio visual temperature alarms is included as standard, along with HACCP capability, and automatic defrost. Unit includes a full-perimeter bumper guard along with two (2) flush transport handles on each end of the cart. Cart is furnished with two heavy duty swivel casters and two heavy duty swivel casters with brake.

1000-MR2-1 - Single compartment Mobile Refrigerated Cart



Factory-Installed Options

- Electrical
 - 220V
- Door swing option
 - Right-hand door, standard
 - Left-hand door, optional

1000-MR2-1

Mobile Refrigerated Cart

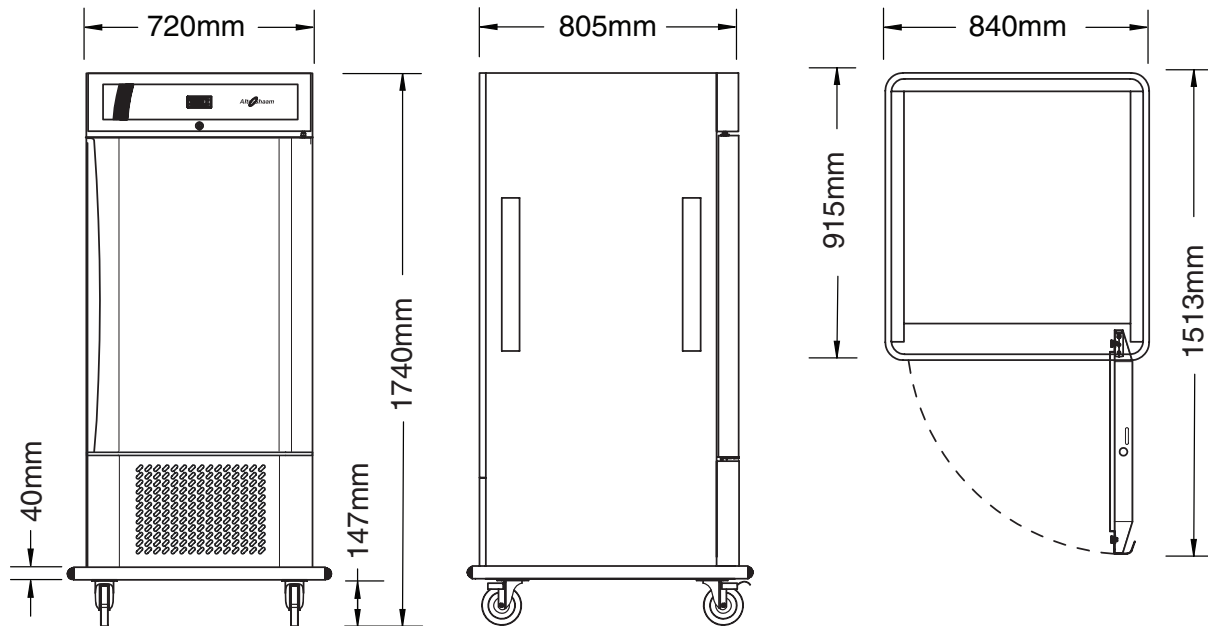



Installation Requirements
<ul style="list-style-type: none"> – Cart must be installed level. – Cart must not be installed in any area where it may be affected by steam, grease, dripping water, extreme temperatures, or any other severely adverse conditions.

Clearance Requirements
Full perimeter bumper accommodates all clearance requirements.

Refrigeration
270g R134a refrigerant Refrigeration duty of 1584 Btu/h Heat of rejection 2060btu/h

Weight	
Net	Ship
130kg	Standard pallet: 155kg Wood crate: 191kg
Shipping dimensions: (L x W x H) 970mm x 890mm x 1920mm	

Dimensions: H x W x D
Exterior: 1740 mm x 840 mm x 915 mm
Interior: 960 mm x 595 mm x 670 mm

Electrical					
V	Ph	Hz	A	kW	
220	1	50/60	2.5	.43	 GB-2099 10A plug
					 CEE 7/7 Plug rated 250V

Product/Pan Capacity
131 kg maximum
Volume maximum: 228 liters
Gastronorm 1/1: Twenty-four (24) 530 mm x 325 mm x 65 mm

Accessories
<input type="checkbox"/> Shelf, Nylon Coated SH-36682



W164 N9221 Water Street • P.O. Box 450 • Menomonee Falls, Wisconsin 53052-0450 • U.S.A.
 Phone: 262.251.3800 800.558.8744 U.S.A./Canada Fax: 262.251.7067 800.329.8744 U.S.A. only
www.alto-shaam.com